

# MIP1400

## Chest Incline Press Machine

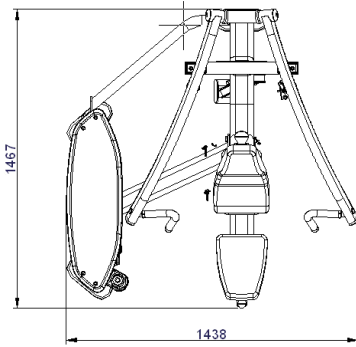

### Console Features:

- A. Personal Coach Function.
- B. Auto Detecting (weight/resistance).
- C. Auto counting.
- D. Auto operation without setting.
- E. Personal program provided.
- F. Display:
  - . a. Training Time
  - . b. Calorie
  - . c. Goal
  - . d. Accumulated Data
  - . e. Counting Down Data





### MIP1400

### Chest Incline Press Machine

Now you have the leverage to safely and efficiently build your chest and arms with the MegaPower Incline Press. Continuous welded, factory assembled connections on the weight and station frame provide extra stability along with durability that extends the life of the station. To ensure user comfort, the MegaPower Incline Press features over 2" of DuraFirm upholstery, double-stitched, fully supported and guaranteed to be tear resistant.

### SPECIFICATIONS

- A. Mainframe: 11 Gauge 1.968" X 5.905" oval tubing (50 x 150 x 3mm)
- B. Upholstery (B/R): CGPC 2"high density foam (ergonomic design)
  - 
  - 
- C. Belt: Tensile strength more than 5,027 Lb. (2,280 Kg)
- D. Shroud: 4T delicate safety cover
- E. Product Weight: 560lbs/255kg(include 210 Lb Stack)
- F. Weight Stack: High-quality weight plates for smooth and durable operation.
  - Standard Weight Stack: 210 Lb. (95.34 kg)
  - a. Optional: 310 Lb. (140.74kg)
  - b. Optional: 410 Lb. (186.14kg)
- G. Dimension: L x W x H, 57" x 58" x 65.5" (1438mm x 1467mm x 1665mm)