

MRM1700 Seated Row Machine

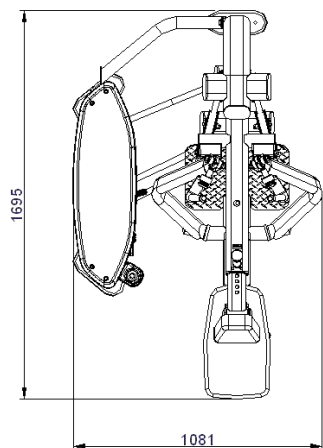

Console Features:

- A. Personal Coach Function.
- B. Auto Detecting (weight/resistance).
- C. Auto counting.
- D. Auto operation without setting.
- E. Personal program provided.
- F. Display:
 - . a. Training Time
 - . b. Calorie
 - . c. Goal
 - . d. Accumulated Data
 - . e. Counting Down Data



MRM1700 Seated Row Machine

The Mega Power Mid Row Machine is engineered optimum back and shoulder isolation. Adjustable hold-down pads add stability for lifts beyond that of a user's body weight. With gracefully curved frames constructed from sleek, power-coated tubing that exhibits a modern, design-forward aesthetic, the Mega Power Mid Row Machine builds form into function and value into a superior modular strength training system.



SPECIFICATIONS

- A. Mainframe: 11 Gauge 1.968" X 5.905" oval tubing (50 x 150 x 3mm)
- B. Upholstery (B/R): CGPC 2"high density foam (ergonomic design)

- C. Belt: Tensile strength more than 5,027 Lb. (2,280 Kg)
- D. Shroud: 4T delicate safety cover
- E. Product Weight: 618lbs/280kg(include 210 Lb Stack)
- F. Weight Stack: High-quality weight plates for smooth and durable operation.
Standard Weight Stack: 210 Lb. (95.34 kg)
 - a. Optional: 310 Lb. (140.74kg)
 - b. Optional: 410 Lb. (186.14kg)
- G. Dimension: L x W x H, 66" x 43" x 65.5" (1695mm x 1081mm x 1665mm)